



TII GROUP

TII GROUP

S SCHEUERLE **N** NICOLAS **K** KAMAG **TII** TIGER

A GLOBAL POWER WORKING FOR YOU
EXPERIENCE THE TII GROUP



TII GROUP



Pfedelbach,
Germany



Champs-sur-Yonne,
France



Ulm,
Germany



Bawal,
India

A GLOBAL POWER WORKING FOR YOU
EXPERIENCE THE TII GROUP



TII GROUP

Transporter Industry International GmbH

2020

Employees:	over 900
Turnover in €	around 200.000.000

TII Group

Success stories: starting from scratch

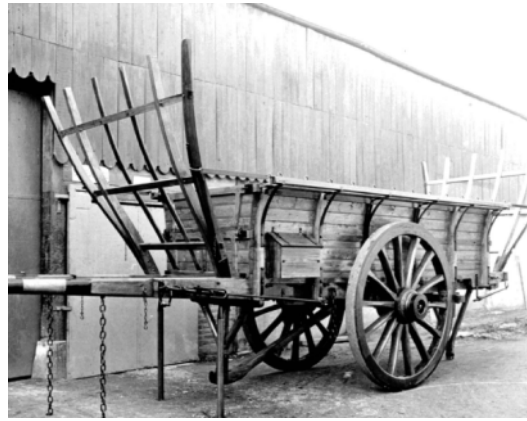

The SCHEUERLE success story starts in 1869 with the acquirement of a forge in Pfedelbach. NICOLAS even began to produce agricultural transport vehicles in 1855. And also KAMAG started the production of heavy-duty transport vehicles in 1969.

The worldwide operating TII Group with its companies SCHEUERLE, NICOLAS, KAMAG and TIIGER now look back on 358 years of accumulated expertise in the production of heavy-duty transport equipment.

SCHEUERLE's first lowbed trailer
Groundbreaking for the transport industry

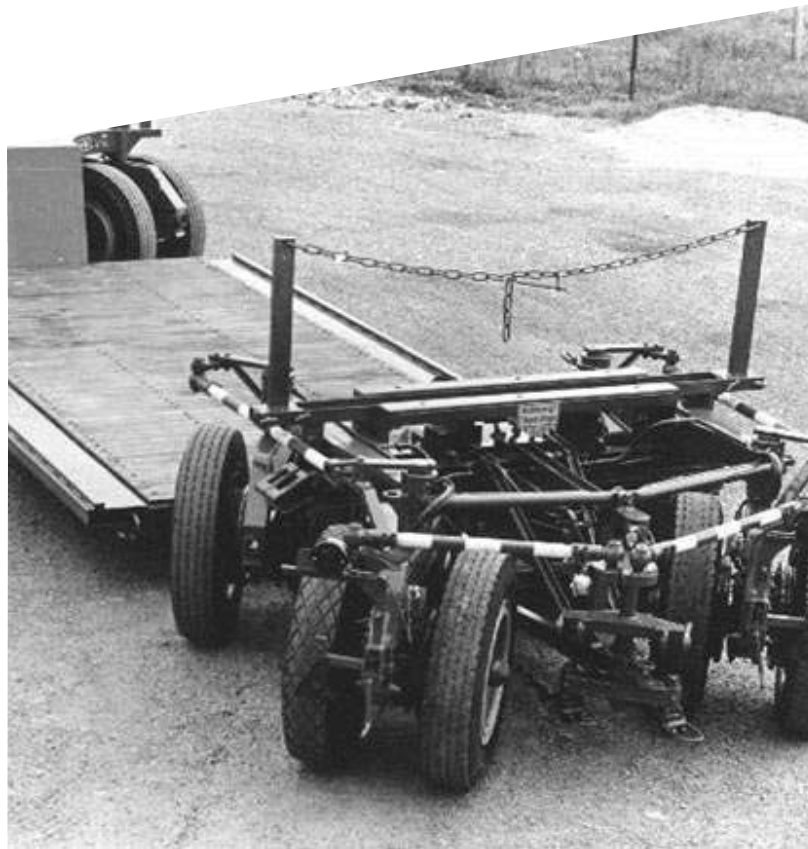

Development of the pendulum axle technology

Today's modern heavy transport came into beginning

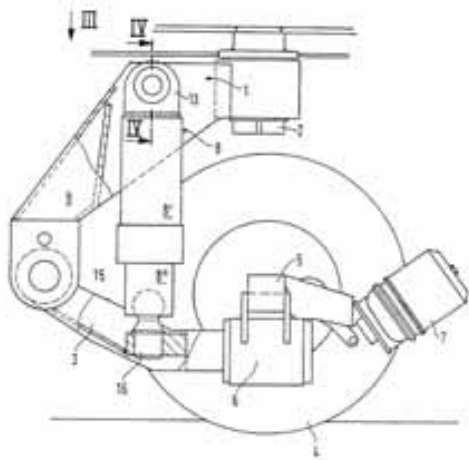

Development of the SPMT

A worldwide synonym for self-propelled modular transporters



TII GROUP AT A GLANCE

WE TURN THE WORLD INTO MOTION



HEAVY DUTY TRANSPORTATION ON PUBLIC ROADS



WIND INDUSTRY



PLANT CONSTRUCTION



BRIDGE AND TUNNEL CONSTRUCTION



SHIPYARD INDUSTRY



STEEL INDUSTRY

TII GROUP AT A GLANCE

WE TURN THE WORLD INTO MOTION



Mining



TERMINAL LOGISTIC



AEROSPACE INDUSTRY



SPECIAL VEHICLES

TRANSPORTATION ON PUBLIC ROADS
HEAVY-LOAD VEHICLE COMBINATIONS FOR NEARLY
ALL TRANSPORT APPLICATIONS



TRANSPORTATION ON PUBLIC ROADS

INTERCOMBI POWERBOOSTER, MDEL-R



TRANSPORTATION ON PUBLIC ROADS

EUROCOMBI, EUROCOMPACT



TRANSPORTATION ON PUBLIC ROADS

K25, K25 POWERBOOSTER



TRANSPORTATION ON PUBLIC ROADS

SUPERFLEX, ULTRA LIGHT COMBI



WIND ENERGY INDUSTRY

SPECIAL SOLUTIONS FOR SPECIAL CHALLENGES



WIND ENERGY INDUSTRY

TOWER SECTIONS



WIND ENERGY INDUSTRY

OFFSHORE NACELLES



WIND ENERGY INDUSTRY

ONSHORE NACELLES



WIND ENERGY INDUSTRY

ROTOR BLADES AND ENTIRE ROTOR STARS



WIND ENERGY INDUSTRY

ROTOR BLADE AND TOWER SECTION ADAPTERS



WIND ENERGY INDUSTRY

TOWER SECTIONS AND GRAVITY FOUNDATIONS



WIND ENERGY INDUSTRY

TRIPODS AND MONOPILES



TRACTOMAS

THE MOST POWERFUL PRIME MOVER IN THE WORLD



Development of the TRACTOMAS

The worldwide strongest prime mover



In 1979, NICOLAS develops the Tractomas, a powerful tractor for special operations on- and off-road.



2005, NICOLAS places an entry the Guinness World Records with the TRACTOMAS 10x10.

With more than 1.000 hp the strongest prime mover in the world.

TRACTOMAS







INDUSTRIAL & PLANT CONSTRUCTIONS
CONCENTRATED KNOW-HOW AND ADVANCED
TECHNOLOGY



INDUSTRIAL & PLANT CONSTRUCTIONS

INDUSTRIAL PLANTS



OIL & GAS INDUSTRY

PROVIDING SOLUTIONS FOR UNIMAGINABLE DIMENSIONS



OIL & GAS INDUSTRY

**PROVIDING SOLUTIONS FOR UNIMAGINABLE
DIMENSIONS**



OIL & GAS INDUSTRY

**PROVIDING SOLUTIONS FOR UNIMAGINABLE
DIMENSIONS**



METALLURGY INDUSTRY

SPECIFICALLY DEVELOPED FOR WORKING IN HEAT AND DIRT



METALLURGY INDUSTRY

LIQUID SLAG UP TO 1000°C



METALLURGY INDUSTRY

**TRANSPORTATION OF SEMI-FINISHED AND FINISHED
STEEL PRODUCTS**



METALLURGY INDUSTRY

SCRAP MANAGEMENT



CUSTOMIZED SPECIAL VEHICLES
CREATED FOR SPECIFIC REQUIREMENTS



CUSTOMIZED SPECIAL VEHICLES

OFFSHORE CABLE TRANSPORTER, RAIL CAR
TRANSPORTER, ARCTIC PACKAGES





CUSTOMIZED SPECIAL VEHICLES

BRIDGE SECTION TRANSPORTER



CUSTOMIZED SPECIAL VEHICLES

RADIO TELESCOPE ANTENNA TRANSPORTER



SERVICE

AT YOUR DISPOSAL AROUND THE WORLD



CUSTOMER SERVICE



- / High availability – also in the remotest places on earth
- / Trained technicians, specialists and engineers
- / General overhauls worldwide and on-site
- / Repairs in our workshops or on-site at the customers premises
- / Well-sorted spare parts storage
- / High availability for spare parts (also for old transporters)



TII GROUP
A GLOBAL POWER WORKING FOR YOU

TII GROUP

S SCHEUERLE **N** NICOLAS **K** KAMAG **TII** TIGER